



Rotary Form, Fill and Seal Machines FM 200 - FM 600

Intermittently working rotary machines to form, fill and seal flat or stand-up pouches made from reel, also with reclosure systems.

Application range: Food, Pet Food, Beverages, Pharmaceuticals, Nonfood, Household, Personal Care.

- Duplex, Triplex, Quadro, Quinta, Sexta available
- **8 stations** with maximum format range at highest speed, additional equipment (e.g. Nitrogen gassing)
- Up to 20% saving of packaging material
- Servo driven sealing systems
- Easy access for operators
- Compact, modular design
- Up to 3 filling stations for: Slide doser, auger doser, scales, micro doser for smallest volumes, rotary and valve pumpdoser, flow meter
- Hygienic construction and easy cleaning
- Central operation and visualization via touch screen
- Synchronization with linear and multi-head weigher



Uniquely customized.
Uniquely economical.

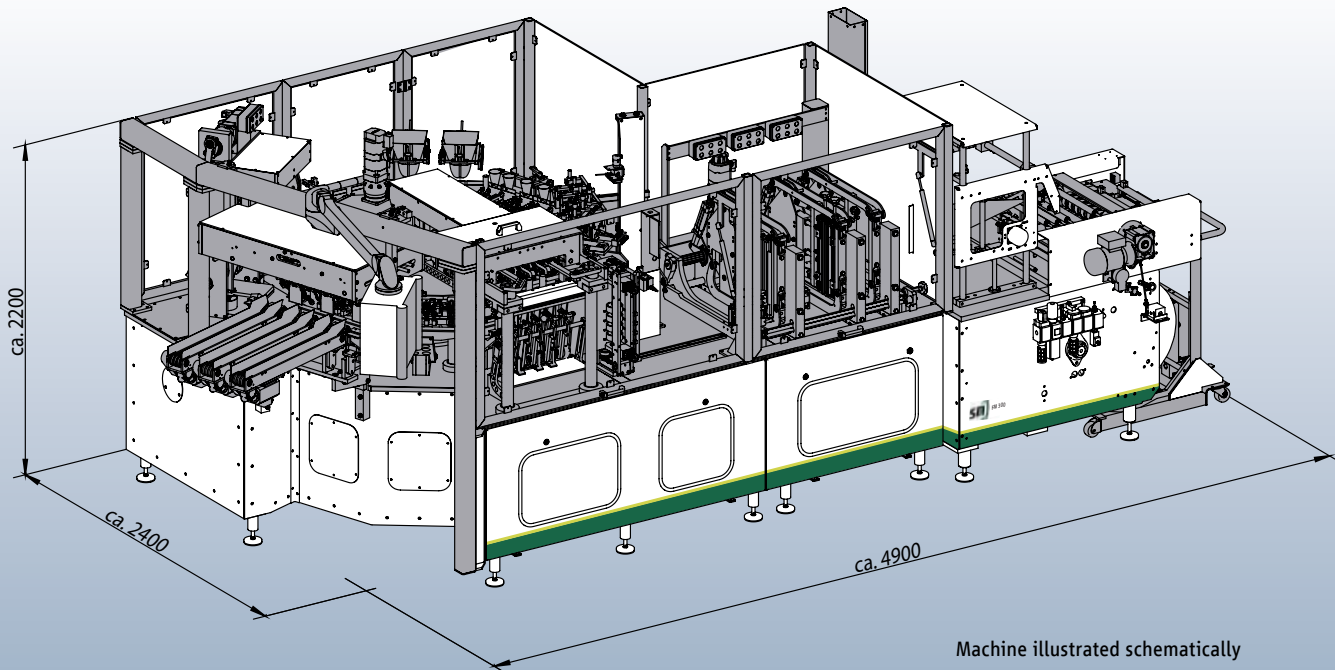

Machine illustrated schematically

Technical details FM 200 - FM 600

Specifications	FM 200 DUPLEX	FM 300 TRIPLEX	FM 400 QUADRO	FM 500 QUINTA	FM 600 SEXTA
Pouch size [mm] ¹⁾	Width 100 - 299 Length 120 - 350	Width 100 - 191 Length 120 - 350	Width 80 - 137 Length 90 - 250	Width 70 - 110 Length 90 - 210	Width 70 - 88 Length 100 - 210
Machine output [Pouches/min]	up to 180*	up to 270*	up to 360*	up to 450*	up to 540*
Packing material	sealable laminated film				
Construction	Standard to process dry products Optional wash down construction				
Safety equipment	Acc. to the international safety regulations e.g. CE , UL, CSA, OSHA				
Electricity power [kVA]	ca. 10 - 30 ¹⁾				
Electricity supply	3 x 400/230V + N + PE, 50/60 HZ ¹⁾				
Voltage [V]	400 / 230 / 24				
Air consumption	ca. 1.000 - 1.500 NI/min, 6 bar ¹⁾				
Machine dimensions L x W x H [mm]	ca. 4.900 x 2.400 x 2.200 ¹⁾				

¹⁾ Depending on configuration. Technical modifications reserved.

Standard equipment	Optional equipment
Pouch control (no pouch – no filling)	Date code systems
Cutting and glueing table	Wash down construction
Film edge control	Ultrasonic sealing
Motor driven roll lifting unit	Reclosure systems
Servo driven sealing systems	Recipe management
Central operation and convenient process control	Reversed image construction
PLC Siemens or Allen Bradley	Nitrogen gassing
Teleservice	(further details on request)

